

PLAN
SCALE: 3/4" = 1'-0"

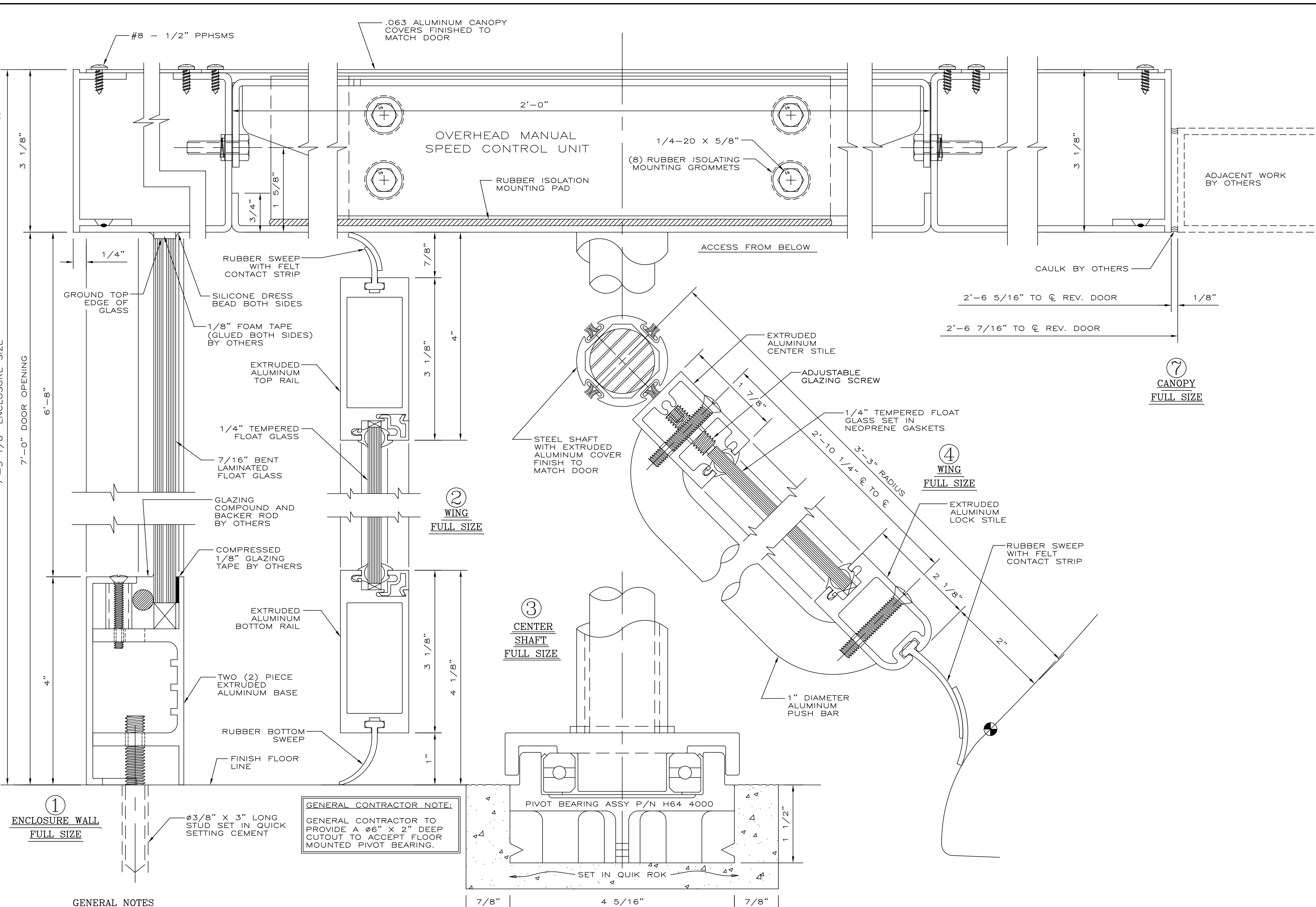

GENERAL CONTRACTOR NOTE:
GENERAL CONTRACTOR TO PROVIDE A #6" X 2" DEEP CUTOUT TO ACCEPT FLOOR MOUNTED PIVOT BEARING.

GENERAL NOTES
CONTRACTOR SHOULD CHECK & TAKE NOTE OF ALL DIMENSIONS AS CRANE (CRANE REVOLVING DOOR) ASSUMES NO RESPONSIBILITY BEYOND MANUFACTURING IN ACCORDANCE WITH THE DIMENSIONS SHOWN ON SHOP DRAWINGS.
APPROVAL INDICATES THAT THIS SHOP DRAWING HAS BEEN CHECKED AND THAT YOU AUTHORIZE US TO FABRICATE MATERIALS AS SHOWN HERE-IN.
REVOLVING DOOR GLAZING MATERIALS, PERIMETER CAULKING (INCLUDING BASE SECTION TO FLOOR) AND CANOPY COVER CAULKING NOT BY CRANE. ALL HOLES IN FLOOR NOT BY CRANE.

MATERIAL TO BE:
EXTRUDED ALUMINUM OF 6063-T6 ALLOY. SHEET ALUMINUM OF 5005-H34 AQ ALLOY. (UNLESS OTHERWISE SPECIFIED)

FINISH TO BE:
CLEAR ANODIZED
AA-M32-C22-A41

GLASS TO BE: CLEAR
1/4" TEMPERED FLOAT FOR WINGS (FACTORY GLAZED)
7/16" BENT LAMINATED FLOAT FOR ENCLOSURE
GLASS TO MEET ANSI Z97.1 AND 16 CFR 1201.
ALL TEMPERED GLASS TO HAVE SAFETY LOGOS. IF ADDITIONAL LOGOS ARE REQUIRED PLEASE SPECIFY.

- HARDWARE SCHEDULE**
- OVERHEAD MANUAL SPEED CONTROL UNIT.
 - FLOOR MOUNTED PIVOT BEARING ASSEMBLY.
 - FULVIEW II PANIC PROOF BOOK-FOLD MECHANISM IN COMPLIANCE WITH ALL APPLICABLE REGULATIONS.
 - LOCKS: SPECIAL REV. DOOR TYPE TWO (2) REQUIRED INSTALLED AT TOP RAILS OF TWO ADJACENT WINGS FOR INTERIOR LOCKING.
 - CYLINDERS: STANDARD SIZE MORTISE TYPE, TWO (2) REQUIRED PER REV. DOOR UNIT, TO BE SUPPLIED BY OTHERS.
 - PUSH BARS: 1" DIAMETER ALUMINUM, FINISH TO MATCH DOOR.
- INSTALLER NOTE:**
BOOK-FOLD TENSION IS NOT PRESET; IT MUST BE ADJUSTED TO MEET BUILDING CONDITIONS.

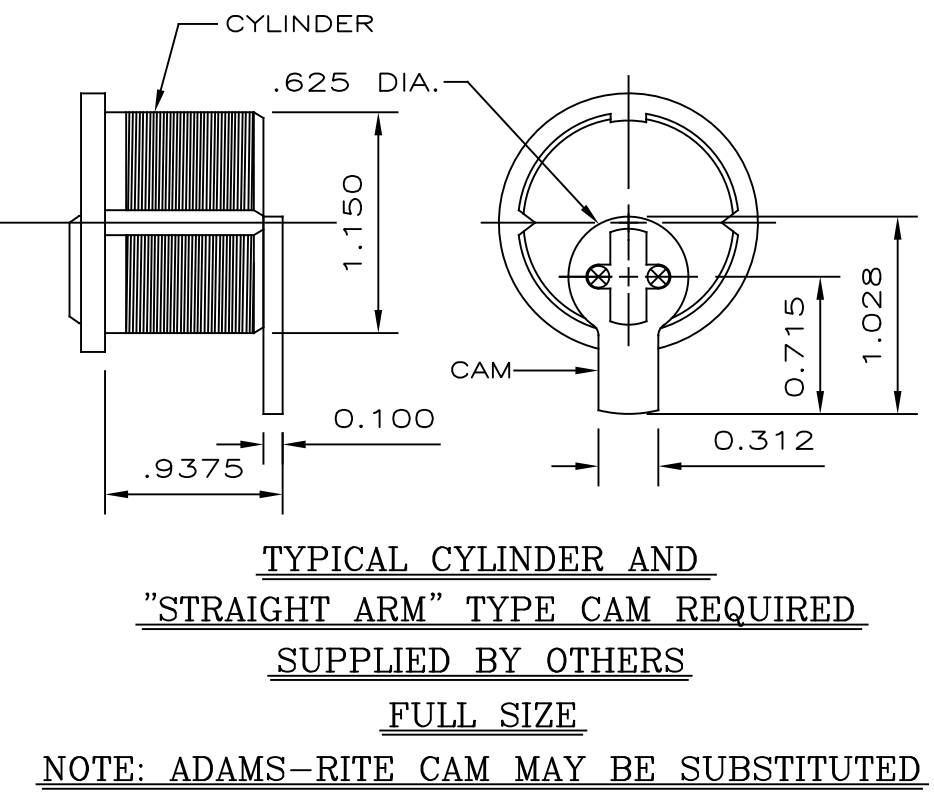

PRIOR TO FABRICATION, SHOP DRAWINGS AND SAMPLES MUST BE FULLY APPROVED AND RETURNED TO DORMAKABA.

Crane dormakaba
PHONE: 717-335-8722 | DORMA DRIVE REAMSTOWN, PA 17567

PROJECT TITLE: **ATTACHMENT PLAN "D"**

| | |
|---------------------|----------------------------|
| LOCATION: | PLEASE ADVISE |
| ARCHITECT: | PLEASE ADVISE |
| GENERAL CONTRACTOR: | PLEASE ADVISE |
| SUB. CONTRACTOR: | PLEASE ADVISE |
| HFG. REP.: | |
| DRAWN BY: JG | MODEL NUMBER / DOOR NUMBER |
| SCALE: AS SHOWN | AL2000-M |
| CHECKED BY: BKA | |
| DATE: 01/04/22 | SHEET: 1 OF 2 |
| REVISIONS | DRAWING NO.: XXXX |

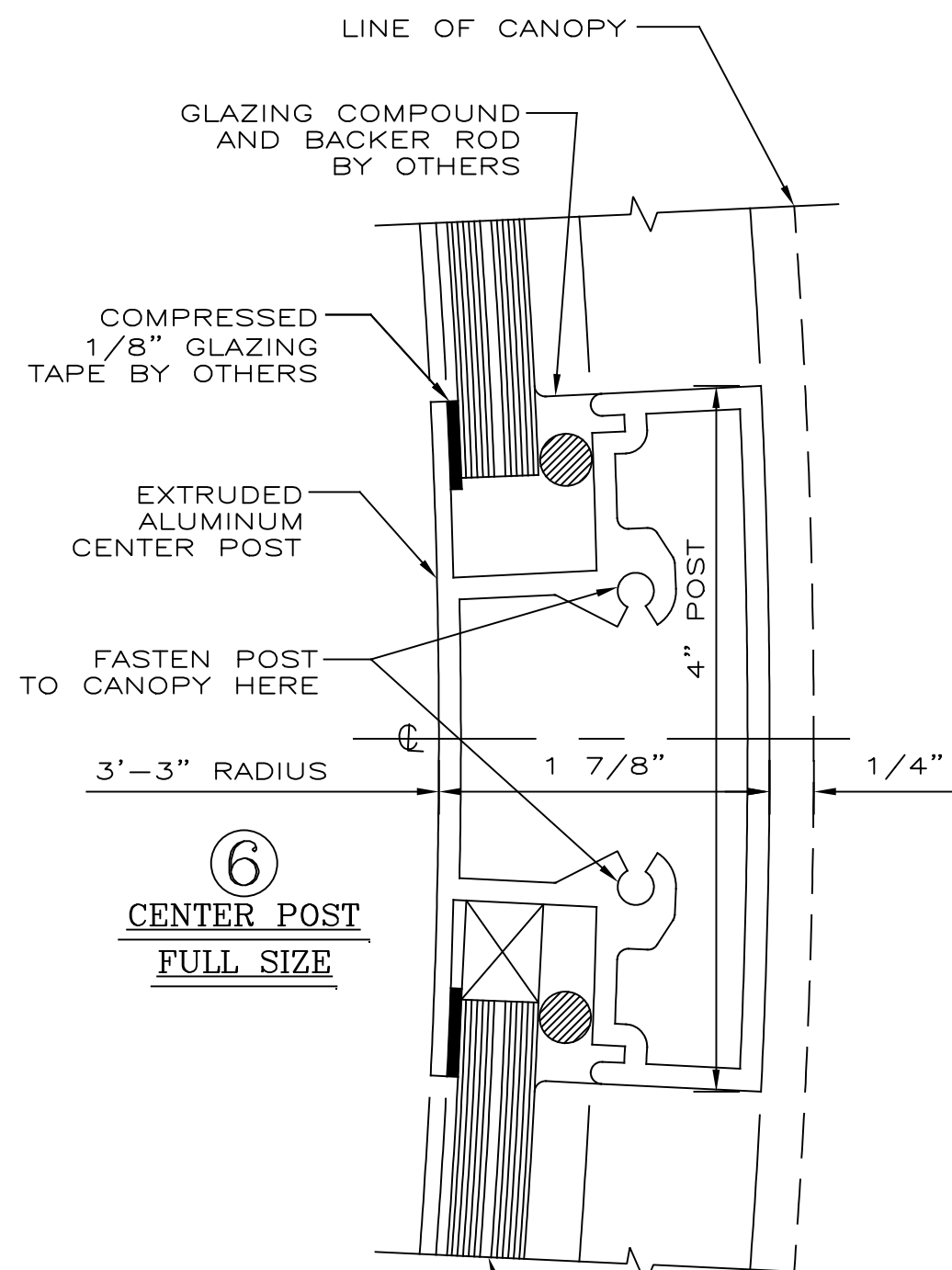

⑥
CENTER POST
FULL SIZE

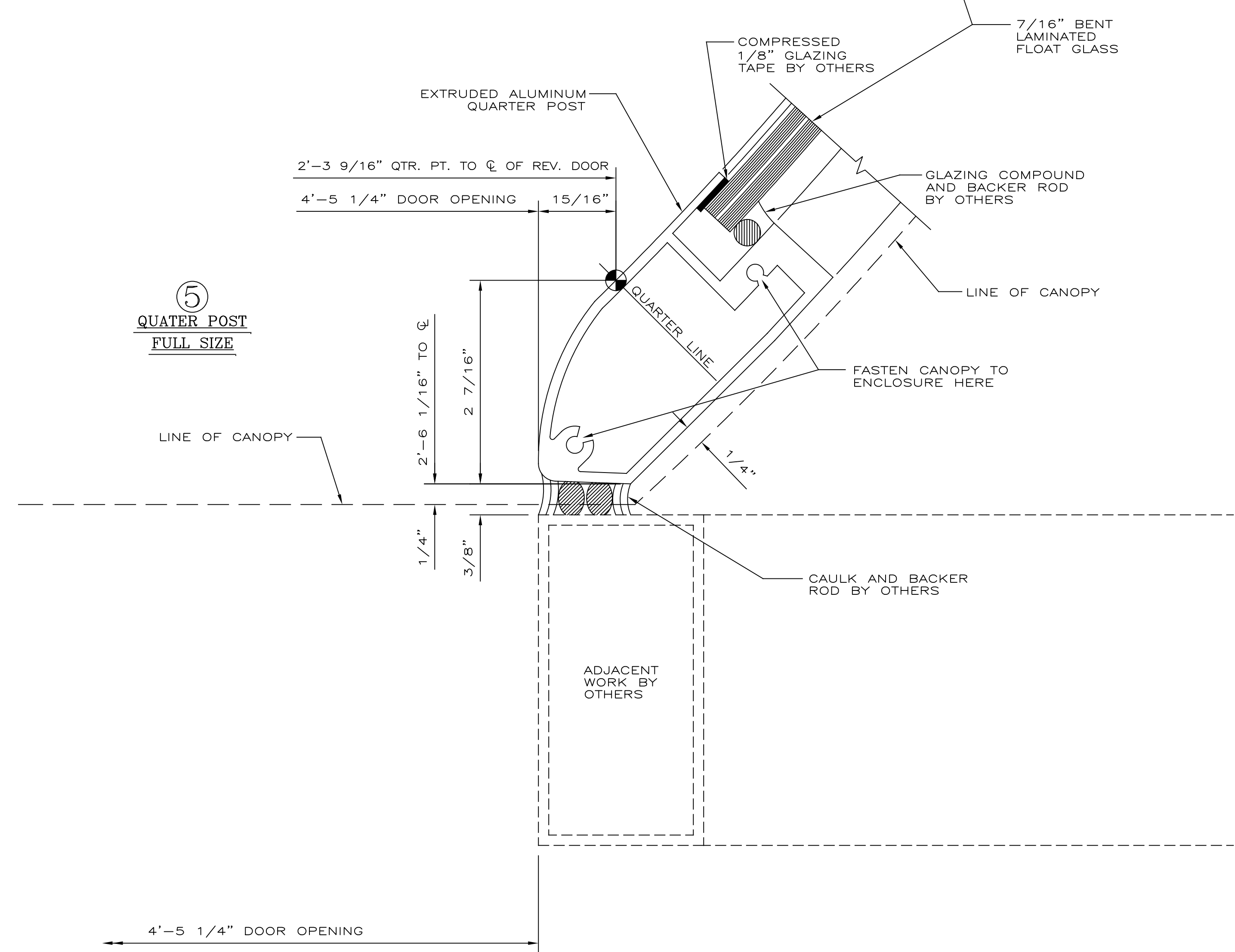

⑤
QUATER POST
FULL SIZE

PRIOR TO FABRICATION, SHOP DRAWINGS AND SAMPLES MUST BE FULLY APPROVED AND RETURNED TO DORMAKABA.



PHONE : 717-535-8722 | DORMA DRIVE REAMSTOWN, PA 17567

PROJECT TITLE:
ATTACHMENT PLAN "D"

| | |
|----------------------|----------------------------|
| LOCATION : | PLEASE ADVISE |
| ARCHITECT : | PLEASE ADVISE |
| GENERAL CONTRACTOR : | PLEASE ADVISE |
| SUB. CONTRACTOR : | PLEASE ADVISE |
| HFG. REP. : | |
| DRAWN BY: JG | MODEL NUMBER / DOOR NUMBER |
| SCALE: AS SHOWN | AL2000-M |
| CHECKED BY: BKA | |
| DATE: 01/04/22 | SHEET: 2 OF 2 |
| | DRAWING NO.: XXXX |

| REV # | DATE | REVISED BY | CHK'D |
|-------|------|------------|-------|
| | | | |
| | | | |
| | | | |
| | | | |

REVISIONS